

12oz
 Item number: **8053**

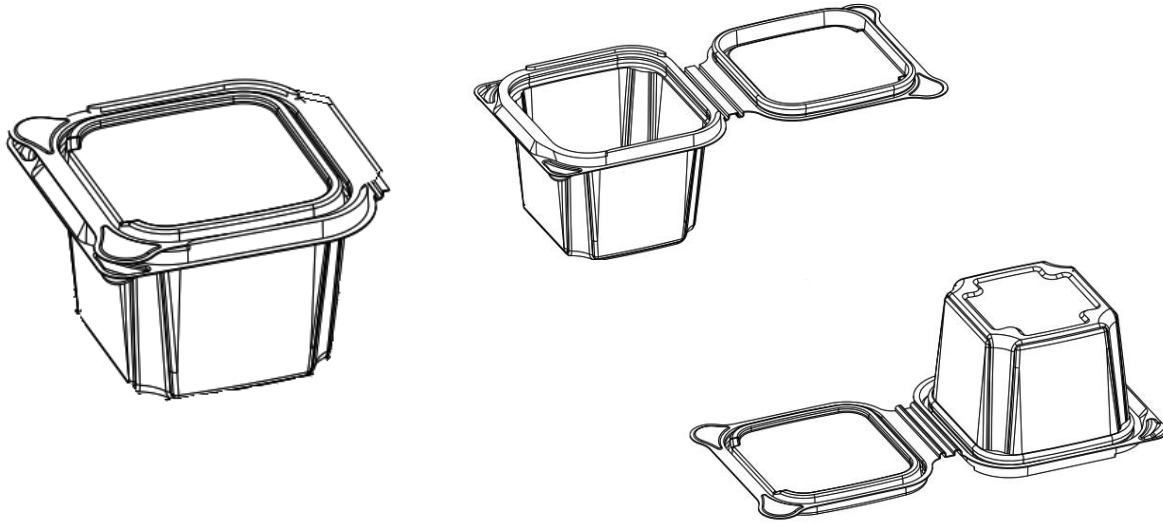

Product Information

Product Dimension in (L x W x H):	4 3/4 x 4 5/8 x 3 1/16
Product Gram weight:	25g
Case Dimension (in inches):	22 1/2 X 19 5/8 X 9 3/4
Case Pack:	300
Gross Weight (in lbs.):	19
Net Weight (in lbs.):	17
Pallet Pattern (TI x HI)	4x8
Sustainable:	YES
Color:	Clear
Material:	PET
Shape:	Square
Product Type:	Clamshell
Capacity:	12oz

Royal Interpack North America, Inc.
 475 Palmyrita Avenue, Riverside, CA 92507 • Tel: (951) 787-6925 Fax: (951) 241-7704

